

ANTICA TILE

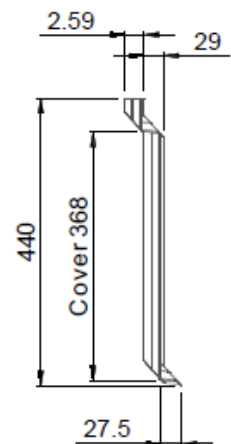

Product Specifications	
Overall Length	1330mm
Length of Cover	1220mm
Width of Cover	368mm
Roof Cover / Tile	0.47m ²
Tiles / m ²	2.15
Weight / Tile	3.0kg
Weight / m ²	6.4kg
Minimum Roof Pitch	12°

Dimensions and weights given are nominal

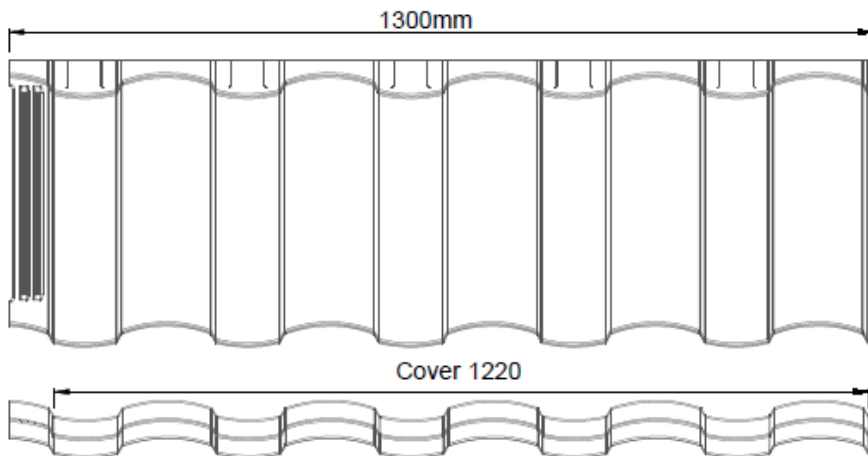

ANTICA TILE INSTALLATION

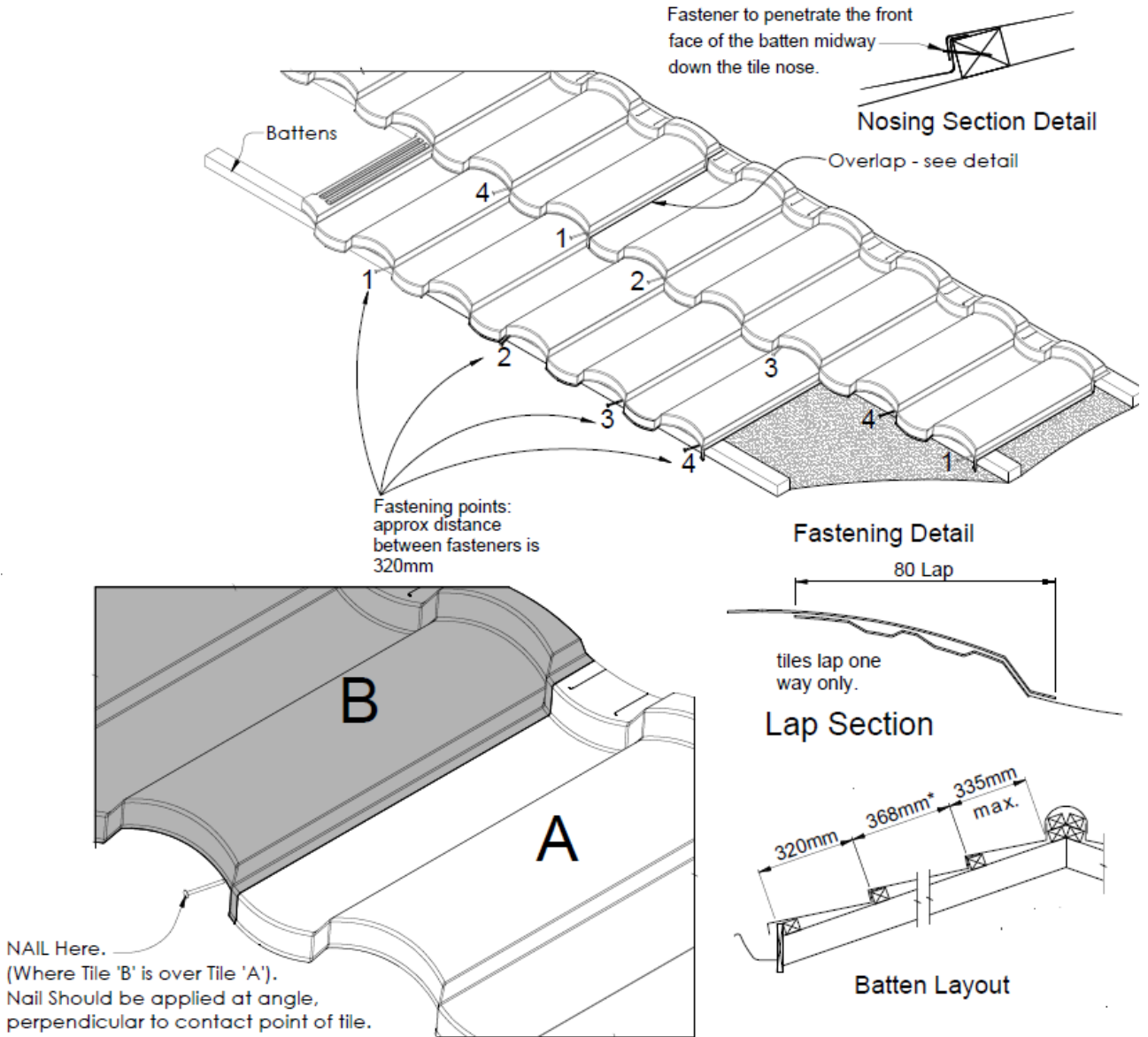

Dimensions and weights given are nominal

Fixing

- The nose of each panel is held down at 5 points
- This comprises 4 nails as per the diagrams plus the nailed overlap panel

Fastening panels in Cyclone Areas

- Where a building has been designed outside the scope of NZS 3604, panels on buildings with a wind load design of above 3.8kPa should be fastened at approx. 160mm spacing (each module).